



Spec. No.:
Ver: A0
Date: 2022-04-9

Specification Approval Sheet

锂离子聚合物电池规格承认书

Model 型号: KE60400-95mAh

Type 类型: Li-ion polymer

Approval 批准	Pack 制定	Cell 制定
Customer Approval 客户回签		

深圳市科恩瑟尔电池有限公司

地址: 中国广东省深圳市龙华区
大浪街道华荣路龙兴商业大厦 5008

Shenzhen Coincell Battery Co., Ltd.

Address: 5008 Longxing commercial building, Huarong Road, Dalang Street Longhua District,
Shenzhen City, Guangdong Province, China
Kelly.shu@coincell.cn
www.coincell.cn
0086-17620552786



深圳市科恩瑟尔电池有限公司
Shenzhen Coincell Battery Co., Ltd.

History of specification

规格书修订记录

Date 日期	Contents 内容	Remarks 备注
2020-04-09	First issue 新发行	A/0



Contents

1	Scope 范围	4
2	Product and Model Name 产品种类及型号	4
2.1	Product 产品种类	4
2.2	Model Name 产品型号	4
3	Technical parameters 主要技术参数	4
4	Dimensions and Appearance 外形尺寸及外观	5
4.1	Dimensions 外形尺寸	5
4.2	Appearance 外观	5
5	Performance 性能	6
5.1	Standard Test Conditions 标准测试条件	6
5.2	Measuring Instrument or Apparatus 测试设备	6
5.3	Standard Charge 标准充电	6
5.4	Rest Period 搁置时间	6
5.5	Initial Performance Test 初始性能测试	5
5.6	Electrical Performance 电性能	6
5.7	Mechanical Performance 机械性能	8
5.8	Safety Performance 安全性能	9
6	Handling Instructions 电池使用指南	10
7	Period of Warranty 保质期	14
8	Delivery Condition 运输条件	14
9	Note 备注	14



深圳市科恩瑟尔电池有限公司
Shenzhen Coincell Battery Co., Ltd.

1 Scope 适用范围

This specification is applied to Lithium Polymer Battery manufactured by Shenzhen Coincell Battery Co., Ltd.

本产品规格书适用于深圳市科恩瑟尔电池有限公司生产的聚合物锂离子电池。

The product is ROHS compliant.

本产品符合 ROHS 标准。

2 Product and Model Name 产品种类及型号

2.1 Product 产品种类: Lithium Polymer Battery 聚合物锂离子电池

2.2 Model Name 产品型号: KE60400-90mAh

3 Technical parameters 主要技术参数

Item 项目		Spec 规格	Remark
3.1 Capacity 容量	Typical 典型	95mAh	Discharge:0.2CmA, 0.2C 放电
	Minimum 最小	88mAh	
	Energy 能量	0.333Wh	
3.2 Nominal Voltage 额定电压		3.7V	Discharge:0.2CmA 0.2C 放电(18.0mA)
3.3 AC Impedance Resistance 内阻		≤400mΩ	
3.4 Discharge Cut-off Voltage 放电截至电压		3.00V	
3.5 Charge Voltage 充电截止电压		4.20V	
3.6 Max. Charge Voltage 最大充电电压		4.20V	
3.7 Charge Time 充电时间		Approx 0.5h	Charge: 30min、V≤3.5V、 I=280mA
3.8 Standard charge current 标准充电电流		360.0mA	4.0CmA
3.9 Max. Charge Current 最大充电电流		450.0mA	5.0CmA
3.10 Max. discharge current 最大放电电流		90.0mA	1.0CmA
3.11 Operating Temperature 工作温度	Charge 充电	5~+45℃	
	Discharge 放电	-10~+55℃	
3.12 Charging capacity 充电容量(4分 钟)	280mA Constant current charging: 280mA 恒流充 电	Charging capacity: 18.7mAh 充电容 量: 18.7mAh	V≤3.5V、I=280mA
3.12 Storage Temperature 储存温度	Less than 1 months 小于 1 个月	-10~+45℃	Recommended storage temperature: 20℃, at the transportation
	Less than 6 months 小于 6 个月	-10~+35℃	

4 Product size and Appearance 电池成品尺寸及外观

4.1 Product size 成品尺寸

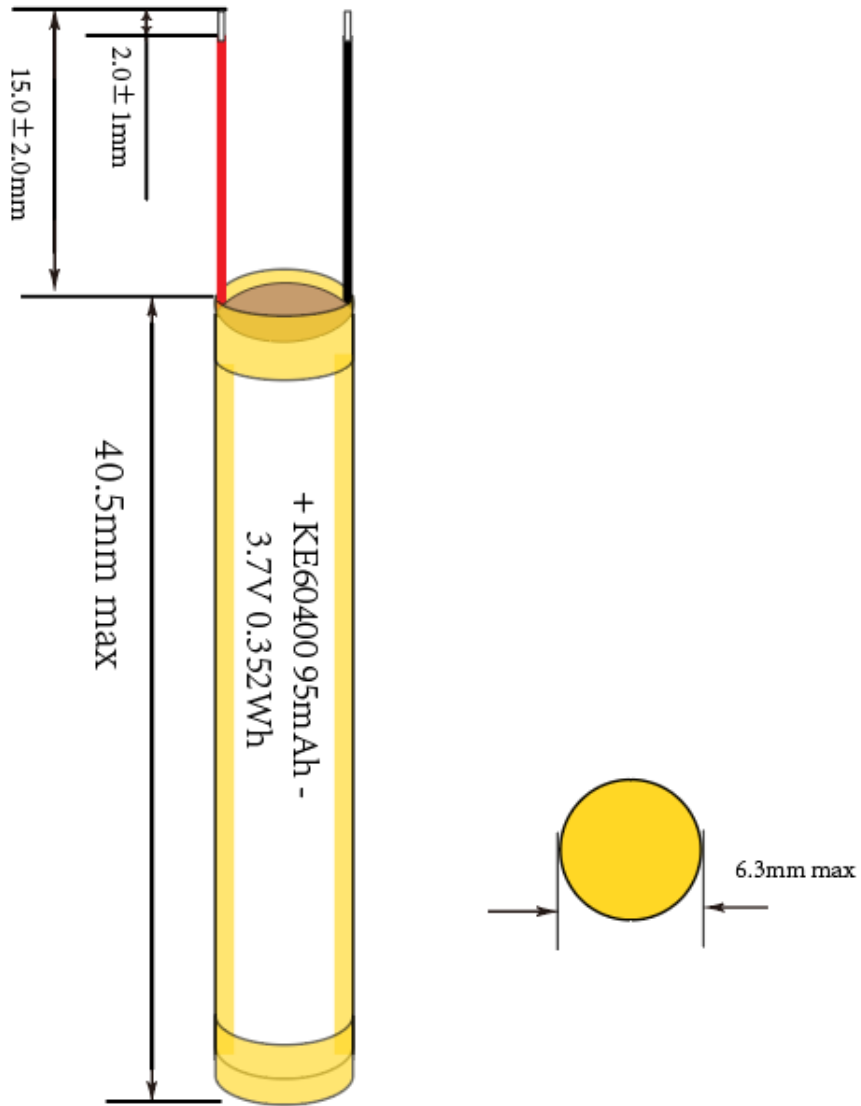

Ø=直径(mm)	H=长度(mm)	负极转镍长度(mm)	L 线材规格(mm)
6.3Max	40.5Max	1.5 (宽) *0.1 (厚) /40 ± 3	28#铁氟龙/15 ± 2、线径 0.65 ± 0.05mm

4.2 Appearance 外观

There shall be no such defect as scratch, crack, rust, leakage, which may affect Commercial value of battery.

电池外表面清洁，无电解液泄漏，无明显的划痕及机械损伤，无变形，无影响电池价值的其它外观缺陷。



5 Performance 性能

5.1 Standard Test Conditions 标准测试条件

Test should be conducted with new batteries within one month after shipment from our factory and the cells shall not be cycled more than five times before the test. Unless otherwise defined, test and measurement shall be done under temperature of $25\pm 2^{\circ}\text{C}$ and relative humidity of 45~85%. The test results are not affected evidently by such conditions of temperature 15~30 $^{\circ}\text{C}$ or humidity 25~85%RH.

测试电池必须是本公司出厂时间不超过一个月的新电池，且电池未进行过五次以上充放电循环。除非其它特殊要求，本产品规格书规定的测试条件为：温度 $25\pm 2^{\circ}\text{C}$ ，相对湿度 45%~85%。如果已经证明测试结果不受这些测试条件影响，实验也可以在温度 15~30 $^{\circ}\text{C}$ ，相对湿度 25%~85%的条件下进行。

5.2 Measuring Instrument or Apparatus 测试设备

5.2.1 Dimension Measuring Instrument 尺寸测量工具

The dimension measurement shall be implemented by instruments with equal or more Precision scale of 0.01mm.

测量尺寸的仪器精度应大于等于 0.01mm

5.2.2 Voltmeter 万用表

Standard class specified in the national standard or more sensitive class having inner impedance more than 10 M Ω

万用表测量电压及电流的准确度应不低于 0.5 级，测量电压时内阻不应小于 10 M Ω 。

5.2.3 Impedance Meter 阻抗法

Impedance shall be measured by a sinusoidal alternating current method (1kHz LCR meter).

内阻测试仪测量原理应为交流阻抗法（1kHz LCR）。

5.3 Standard Charge 标准充电

5.3.1 Standard charge current 标准充电电流

4.0CmA=360.0mA

5.3.2 Max. Charge Current 最大充电电流

5.0CmA=450.0mA

5.3.3 Fully Charge Condition 满充条件

Fully charge condition: Constant current 4.0CmA to 4.20V, Constant voltage 4.20V to 0.1C in all at $25\pm 2^{\circ}\text{C}$.

满充条件：4.0C 恒流充至 4.20V，然后 4.20V 恒压充电至截止电流为 0.1C，在 $25\pm 2^{\circ}\text{C}$ 环境下充电；

5.4 Rest Period 搁置时间

Unless otherwise defined, standby 10min after charge, standby 10min after discharge.

如无特殊要求，电池充放电间隔为 10min。



深圳市科恩瑟尔电池有限公司
Shenzhen Coincell Battery Co., Ltd.

5.5 Initial Performance Test 初始性能测试

Item 项目	Measuring Procedure 测试方法	Requirements 要求
(1) Open-Circuit Voltage 开路电压	The open-circuit voltage shall be measured within 24 hours after standard charge. 标准充电后, 24 小时内测量开路电压	≥4.12V
(2) AC Impedance Resistance 内阻	The Impedance shall be measured in an alternating current method (1kHz LCR meter) after standard charge at 25±2°C. 标准充电后, 在 25±2°C 采用交流法测量内阻	≤400mΩ
(3) Minimum Capacity 最小容量	The capacity on 0.2C discharge shall be measured after standard charge at 25±2°C (specified C5). 标准充电后, 搁置 30min, 0.2C 放电至 3.0V, 测试电池容量 (该容量定义为 C5)	C5≥88.0mAh

5.6 Electrical Performance 电性能测试

5.6.1 Temperature Dependence of Capacity (Discharge) 不同温度放电特性

Cells shall meet the discharge capacity requirements listed in the below table under respective discharge temperatures. Low-temperature discharge current of 0.2CmA, high temperature discharge current of 0.5CmA, (2.75V cut-off) after standard charge at 25±2°C.

电池在 25±2°C 标准充电, 然后在 30 分钟内冷却或加热到测试温度。放电前电池在此温度下保持 1 小时, 低温放电电流为 0.2CmA, 高温放电电流为 0.5CmA, 做完一个温度实验后, 电池在室温下放置 2h 然后进行充电 (25±2°C), 要求如下:

Discharge Temperature 放电温度	-10°C	25°C	55°C
Discharge Capacity 放电容量	60%	100%	95%

5.6.2 Cycle Life 循环性能

10min rest period after standard charge, 1.0CmA discharge to a cut-off voltage of 3.0V, 10min rest period, the test shall be terminated when Discharging Capacity ≤70% C5 of Initial Capacity in three consecutive cycles. Standard charge and discharge at 25±2°C.

标准充电后, 搁置 10min, 1.0CmA 放电至 3.0V, 搁置 10min, 重复上述步骤进行循环, 直至电池放电容量连续 3 次 ≤ 额定容量 70%, 测试温度 25±2°C (影响电池循环性能的重要参数), 要求如下:

Cycle time ≥ 500 times
循环次数 ≥ 500 次

5.6.3 Shelf Life 荷电保持能力

Item 项目	Measuring Procedure 内容	Requirements 备注
Storage Characteristics 1 贮存特性 1	1 The capacity on 0.5CmA discharge shall be measured after standard charge and then storage at 25±2°C for 30 days. 标准充电后电池在 25±2°C 的环境中贮存 30 天, 测试 0.5CmA 放电容量 (保持容量)	Remaining Capacity ≥85% C5 容量保持 ≥85% C5



深圳市科恩瑟尔电池有限公司
Shenzhen Coincell Battery Co., Ltd.

	2	After above measured Remaining capacity, the capacity on standard discharge shall be measured after standard charge. 0.5CmA 循环 3 次, 测试恢复容量 (3 周循环的最大放电容量)	Recovery capacity ≥92% C5 容量恢复≥92% C5
Storage Characteristics 2 贮存特性 2	1	The capacity on 0.5CmA discharge shall be measured after standard charge and then storage at 60±2°C for 3days. 标准充电后电池在 60±2°C 的环境中贮存 3 天, 测试 0.5CmA 放电容量 (保持容量)	Remaining Capacity ≥80% C5 容量保持≥80% C5
	2	After above measured Remaining capacity, the capacity on standard discharge shall be measured after standard charge. 0.5CmA 循环 3 次, 测试恢复容量 (3 周循环的最大放电容量)	Recovery capacity ≥90% C5 容量恢复≥90% C5

5.6.4 Long Time Storage Characteristics 长期贮存性能

After about half charge after a period of storage at 25 ±2°C for one year (365 days). The recovery available capacity is ≥85% C5. The capacity is determined with the capacity of the by the most of preceding three cycles.

进行该项实验的电池应选生产日期到实验日期不足 3 个月的电池, 贮存前给电池充入 50%的容量, 然后开路搁置 365 天, 在 25±2°C 的环境条件下 0.2CmA 循环 3 次, 测试恢复容量 (3 周循环的最大放电容量), 要求如下: 容量恢复≥85% C5。



深圳市科恩瑟尔电池有限公司
Shenzhen Coincell Battery Co., Ltd.

5.7 Mechanical Performance 机械特性

Item 项目	Measuring Procedure 测试方法	Requirements 要求
Vibration test 振动	<p>After standard charge, the battery is to be tested as following conditions: Amplitude:0.19mm Frequency:10~55Hz(sweep:1Hz/min) Direction: X/Y/Z axis for 30min. The battery is to be tested in three mutually perpendicular to each axis. 标准充电后, 将电池安装在振动台上, 在 X、Y、Z 三个垂直方向进行实验, 振动频率在 10~55Hz 间以 1Hz/min 的速度变化, 位移振幅: 0.19mm, 往复振动 30min。</p>	<p>No fire, no explosion, no smoking . 电池无漏液、冒烟或爆炸,</p>
Drop Test 自由跌落	<p>Drop the battery in the shipment condition(full-charge)from 1m height onto 18~20 mm or thicker concrete with p-tile on it 1 times each of obverse and inverse directions at 25±2°C 电池振动试验结束后按下列条件进行自由跌落试验: 跌落高度: 1.0m; 承接物: 18~20mm 厚硬木板; 跌落方向: 沿水平方向正反面各跌落一次。</p>	<p>No fire, no explosion, no smoking 电池无漏液、冒烟或爆炸</p>
Constant Humidity and Temperature Characteristics 恒定湿热	<p>Under the temperature of 20±5°C, after charging the battery with 0.5C, then put the battery into the constant temperature and humidity oven with 55±2°C and 90~95% for 48h, the battery should be no obvious deformation, leakage, rust, smoking and explosion. After testing take out the battery then rest for 2h under the temperature of 20±5 °C , discharge with 1C to3.0V. 在 20±5°C条件下, 电池按 0.5C 充电结束后, 放入 55±2°C, 湿度 90~95%的恒温恒湿箱内 48h, 电池应无明显变形、漏液、生锈、冒烟或爆炸, 试验结束后将电池取出搁置 2h, 在 20±5°C条件下, 以 1C 放电至 3.0V。</p>	<p>discharge capacity≥60% C5 放电容量≥80% C5</p>



深圳市科恩瑟尔电池有限公司
Shenzhen Coincell Battery Co., Ltd.

5.8 Safety Performance 安全性能

Item 项目	Measuring Procedure 内容	Requirements 要求
Short-Circuit Test 短路测试	After standard charge, the battery is to be short-circuited by connecting the positive and negative terminals of the battery with copper wire having a maximum resistance load of 0.2Ω. 标准充电后，用 0.2Ω 的铜线短路电池的正负极。	No explosion, no fire. The temperature of the exterior cell casing shall not exceed 160°C. 不爆炸，不起火，电池外部温度不超过 160°C。
Heating Test 热冲击测试	A battery is to be heated in a gravity convection or circulating air oven. The temperature of the oven is to be raised at a rate of 5±2°C/min to a temperature of 130±2°C at which temperature the oven is to remain for 30 minutes before the test is discontinued. 电池放于热箱中，温度以（5±2°C）/min 的速率升至 130±2°C 并保温 30min。	No explosion, no fire. 不爆炸，不起火
Abnormal Charging Test 过充电测试	After standard charge, the battery is subjected to a charging current by connecting it to a dc-power supply. The beginning current is 3.0C, which is to be obtained by connecting a resistor of specified size and rating in series with the battery; the voltage of the dc-power supply is 4.6V. The test time is 2.5 hours. 标准充电后，电池及滑动变阻器串联于一恒流恒压源，电压调节为 4.6V，通过滑动变阻器调节电流至 3.0CmA，然后对电池以 3.0CmA 充电。测试时间为 2.5H。	No explosion, no fire. 不爆炸，不起火
Overdischarge Test 过放电测试	The fully discharged cell is continually discharged for 24h with the (30×n) Ω load at 23±2°C. 电池在环境温度 23±2°C 的条件下，以 0.2C5A 放电至终止电压后，外接(30×n)Ω 负载放电 24h。	No explosion, no fire. 电池不起火、不爆炸

6. Protection Circuit 保护电路

6.1 Circuit Diagram 电路原理图

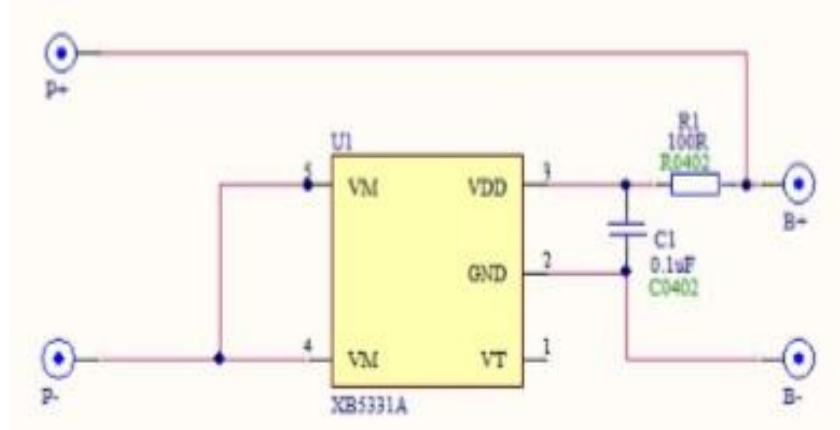

6.2 PCM BOM

NO.	Description	Symbol	Model/Spec.	unit	Q'ty
1	贴片 IC	U1	XB5333	PCS	1
2	贴片电阻	R1	100 Ω, ±5%, 1/10W	PCS	1
3	贴片电容	C1	0.1μF, -20~+80%, 50V	PCS	1
4	FPCB	FPCB	T211-A 双层, 绿油, 喷锡	PCS	1

6.3 PCM parameter PCM 参数要求

NO	Item 项目	Criteria 标准
1	Over-charge Protection Voltage 过充电保护电压	4.225~4.275V
2	Over-discharge protection Voltage 过放保护电压	2.70~2.90V
3	放电过流保护电流 Over current protection current	0.20~0.25A
5	Current consumption in normal operation 工 作时消耗电流	10uA MAX
6	Inner resistance 内阻	65mΩ MAX
7	Input voltage (B+ to B-) 输入电压 (B+与B-间)	-0.3~12V



8	0V battery charge function (0V 充电功能)	Available
---	--------------------------------------	-----------

7 Handling Instructions 电池使用指南

Read and observe the following warnings and precautions to ensure correct and safe use of Li-ion batteries.

认真阅读下面的注意事项，确保正确使用锂离子电池。深圳市科恩瑟尔电池有限公司对违反下述注意事项而产生的任何问题不予负责。

Danger! 危险!

Failure to observe the following precautions may result in battery leakage, overheating, explosion and/ or fire. 不仔细阅读下述事项可能导致电池泄露、爆炸或起火。

- 1) Do not immersed cells in liquid (water, fruit juice, coffee, etc.) or get wet
严禁将电池浸入液体中（水、果汁、咖啡等）或弄湿；
- 2) Do not use or store the battery near sources of heat such as a fire or heater.
勿在热源（如火或加热器）附近使用或贮存电池；
- 3) Do not put the battery into a fire or apply direct heat to it.
勿将电池投入火中或给电池加热；
- 4) Do not strike, throw or subject the battery near a fire or in extremely hot conditions.
禁止将电芯投放到较热的容器里。
- 5) Do not reverse the positive (+) and negative (-) terminals.
勿将正负极接反；
- 6) Do not connect the battery directly to wall outlets or car cigarette-lighter sockets.
勿将电池直接连接到墙上插座或车载点烟式插座上；
- 7) Do not short-circuit the battery by connecting wires or other metal objects to the positive (+) and negative (-) terminals.
禁止用导线或其它金属物体将电池正负极短路；
- 8) Do not carry or put the battery together with necklaces, hairpins or other metal objects.
禁止将电池和项链，发夹和其它金属物品放置在一起。

Warning! 警告!

Failure to observe the following precautions may result in battery leakage, overheating, explosion and/ or fire. 不仔细阅读下述事项可能导致电池泄露、爆炸或起火。

- 1) Do not place the battery in a microwave oven or pressurized container.
禁止将电池置入微波炉或压力容器中；
- 2) Do not use the battery in combination with primary batteries (such as dry-cell batteries) or batteries of different capacity, type or brand.
禁止与一次电池（如干电池）或不同容量、型号、品种电池组合使用；
- 4) Do not pierce the battery casing with a nail or other sharp object, break it open with a hammer, or step on it.
禁止用钉子或其它尖锐物体刺穿电池壳体，禁止锤击或脚踏电池；
- 5) Do not directly solder the battery terminals.



深圳市科恩瑟尔电池有限公司
Shenzhen Coincell Battery Co., Ltd.

禁止直接焊接电池端子。

6) Do not attempt to disassemble or modify the battery in any way.

禁止以任何方式分解电池。

7) Do not use the battery if it gives off an odor, generates heat, becomes ct the battery to sever physical shock.

如果电池发出异味、发热、变形、变色或出现其它任何异常现象时不得使用；如果电池正在使用或充电，应立即从用电器中或充电器上取出并停止使用；

8) If the battery leaks or emits an odor, immediately remove it from the proximity of any exposed flame. The leaking electrolyte can ignite and cause a fire or explosion.

如果电池泄漏或发出异味，应立即将其从接近明火处移开；泄漏的电解液可能引起火灾或爆炸。

Caution! 注意!

1) Do not use or store the battery where is exposed to extremely hot, such as under window of a car in direct sunlight in a hot day. Otherwise, the battery may be overheated. This can also reduce battery performance and/or shorten service life.

不要使用处于极热环境中的电池，如阳光直射或热天的车内。否则，电池会过热，可能着火（点燃）；同时这样也会影响电池的性能、缩短电池的使用寿命。

2) Use the battery only under the following environmental conditions. Failure to do so can result in reduced performance or a shorten service life. Recharging the battery outside of these temperatures can cause the battery to overheat, explode or catch fire.

只能在上述条件下使用电池，否则将会降低电池的性能或缩短电池的使用寿命。在此温度范围外使用电池可能引起过热、爆炸或起火。

3) The isolated measures are needed between battery (the bare Al layer at side and top sealing) and the PCB, and also between battery and electric equipment: especially avoid the Al layer in packing foil contact to cathode or anode (including electric equipment, otherwise this can cause battery leakage or swelling.

注意在电芯（侧边和极耳封边包装膜断口位置裸露的铝层）与保护板、及电芯与用电器具之间采用绝缘结构措施：特别注意避免出现包装膜铝层与正负极（包括用电器具的带电部分）出现接触的隐患，否则可能造成漏液气胀。

4) Battery is in high temperature surrounding the adhesive side, prohibit open or damaged

电池的周边是在一定的高温下粘合的边，禁止打开或破坏。

5) Battery pole ear is not unusually strong mechanical strength, paying special attention to the anode ear, must be careful operation, ban repeated bending the ear.

电池极耳的机械强度并非异常坚固，特别要注意的是正极耳，必须小心操作，禁止反复的弯折极耳。

6) If the terminals of the battery are dirty, wipe them clean with dry cloth before use. Otherwise, solid electrical contact may not be charged with the equipment, and this can cause power outages or charging to fail.

如果电池的端子变脏，使用前用干布擦干净。否则电池会接触不良，从而引起能量损耗或无法充电。

7) Please use the charger recommended by Shenzhen Coincell Battery Co., Ltd.

请使用深圳市科恩瑟尔电池有限公司推荐的充电器；

8) Keep the batteries out of the reach of children. If a child somehow swallows a battery, seek medical attention immediately.

电池应放在小孩接触不到的地方，如果小孩不小心吞咽电池 应立即寻求医疗救助；

9) In cases where children use the battery, instruct them on the contents of the user's guide and keep



深圳市科恩瑟尔电池有限公司
Shenzhen Coincell Battery Co., Ltd.

an eye on them to ensure that the battery is being used correctly.

当小孩使用电池时，需要按用户说明书的内容教他们，并密切注意他们确保正确使用电池。

10) If the battery leaks and electrolyte gets your skin or clothing, immediately rinse the affected area with clean running water. If left as is, skin inflammation can occur.

如果电池漏液，电解液弄到皮肤或衣服上，立即用流动的水清洗受影响区域，否则可能导致皮肤发炎

11) If the battery leaks and electrolyte gets in your eyes, do not rub them. Instead, rinse them with clean running water and immediately seek medical attention. If left as is, electrolyte can cause eye injury.

如果电池漏液后电解液进入眼睛，不要擦，应用水冲洗，立即寻求医疗救助。如不及时处理，眼睛将会受到伤害

12) If a device is not used for an extended period, the battery should be removed and stored in a cool, dry place. Otherwise, resting or reduced performance may occur.

如果设备长期不用，将电池取出并放置在凉爽、干燥的地方，否则，电池可能生锈或性能变差。

13) The voltage for a long time (6 month) storage shall be 3.70V~3.90V range.

长期存储（6个月内）电压范围为：3.7~3.9V。

14) For directions on battery installation and removal, read the instruction manual that accompanies the equipment in which the battery will be used.

阅读用电池的装置说明书，正确进行电池的安装与拆卸。

7 Period of Warranty 保质期

The period of warranty is one year from the date of shipment. Shenzhen Coincell Battery Co., Ltd. guarantees to give a replacement in case of cells with defects proven due to manufacturing process instead of the customers' abuse and misuse.

电池的保质期为出厂后一年。本公司承诺如果在一年中由于电池本身的质量问题，本公司将负责进行调换，如果是由于用户误用而产生的问题，不予调换。

8 Shipment 出货

70% SOC before shipment. The battery Voltage: 3.8~4.0V.

电池在出厂时已充入 70% 的电量，电池电压 3.8~4.0V

9 Amendment of this Specification 产品规格书的修订

This specification is subject to change with prior notice.

本公司有权对本产品规格书进行修订，在对产品规格书修订后深圳市科恩瑟尔电池有限公司将会通知客户。